

Life Cycle Assessment of biomethane provision

Jan Paul Lindner

Dept. Life Cycle Engineering (GaBi)

Chair of Building Physics (LBP)

Universität Stuttgart



Outline

- Life Cycle Assessment methodology
 - Product systems
 - Multitude of environmental impacts

- Biomethane from an environmental point of view
 - Overview
 - Feedstock generation
 - Digestion
 - Upgrading
 - Distribution
 - Use



LCA – product systems

- „Cradle to grave“ approach
 - Resource extraction and processing
 - Materials production, product assembly
 - Use phase
 - End-of-life

- Modular inclusion of other product systems



Potential impact

Climate change, resource consumption, acid rain, summer smog, overfertilisation...

Impact assessment

CO₂ CO NO_x SO₂ NH₃ PO₄³⁻
CF₄ N₂O CH₄ HCl HF NH₄⁺ NO_x ...

Life cycle inventory



Life cycle



LCA – product systems

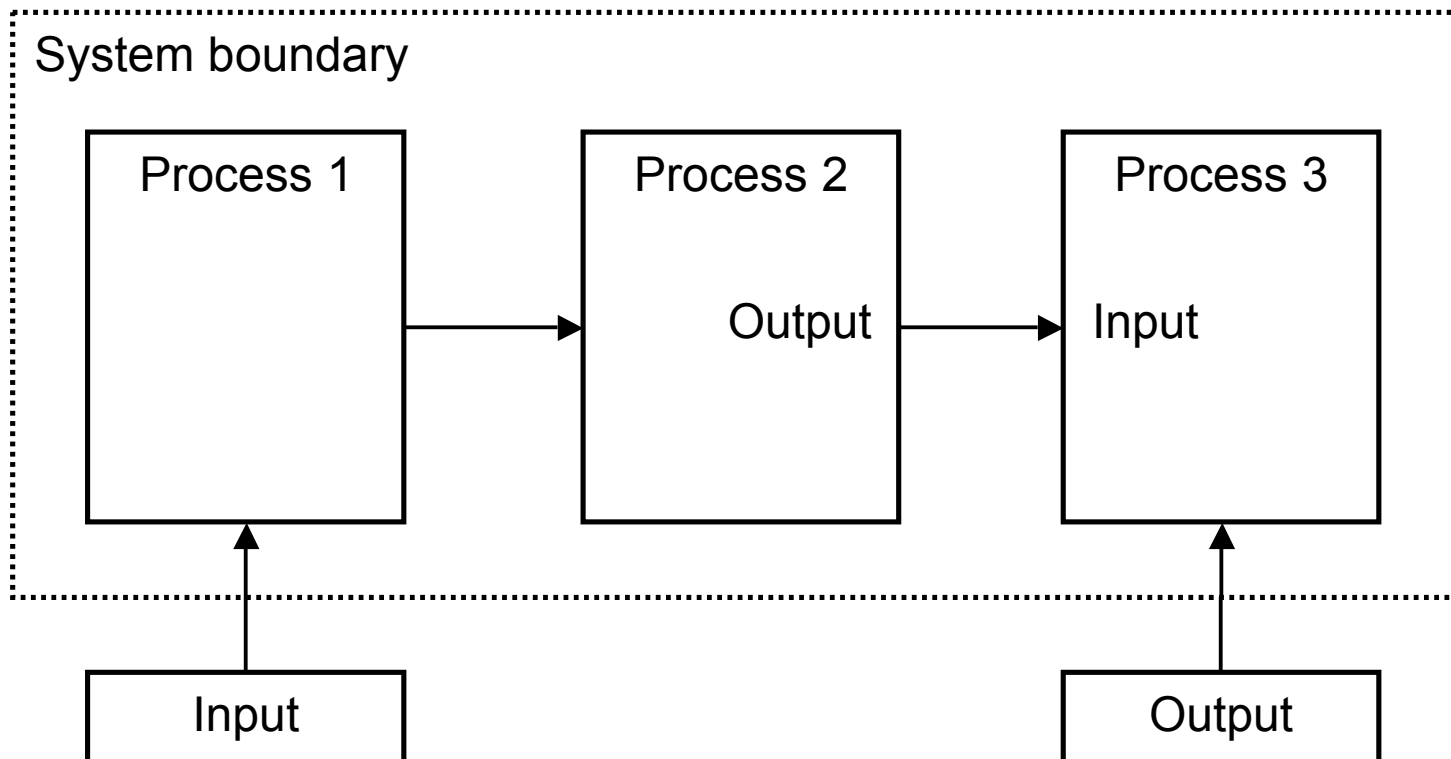

LCA – product systems

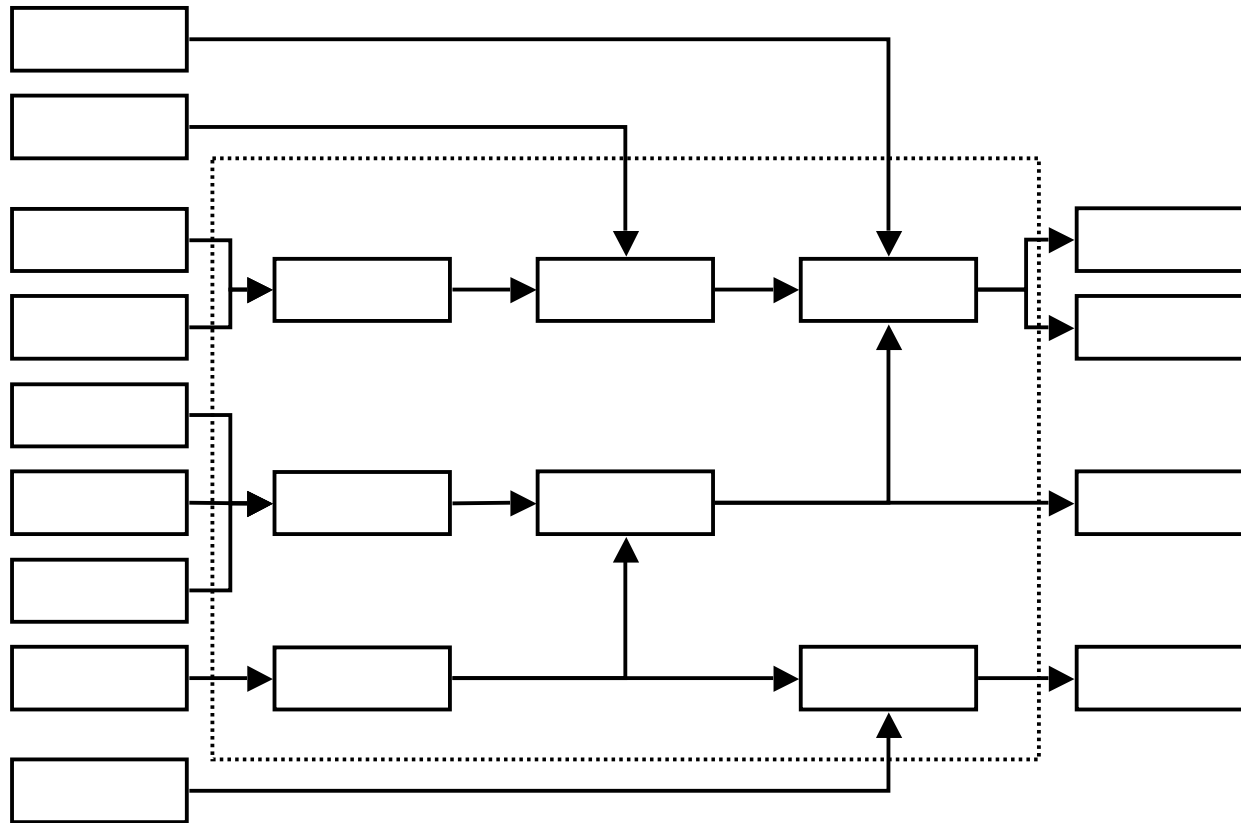

LCA – environmental impacts

- „Environment“ more than just climate
- Impact categories in Biogasmax
 - Global Warming Potential (GWP_{100})
 - Eutrophication Potential (EP)
 - Acidification Potential (AP)
 - Photochemical Ozone Creation Potential (POCP)
 - Primary Energy Demand, renewable/fossil (PE_{ren}/PE_{foss})
- Presentation limited to climate impacts
 - See full report in 2010 for more details



Biomethane – overview

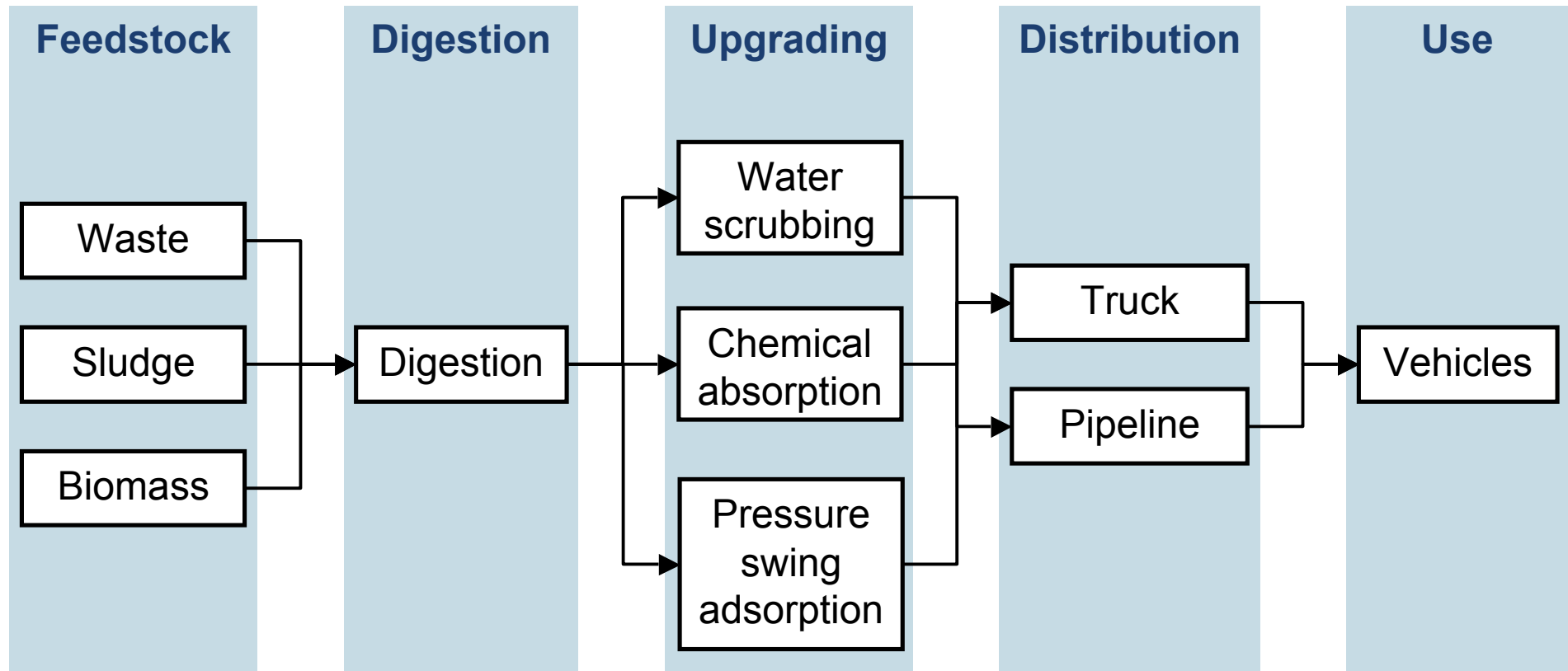

Environmental impact (climate)

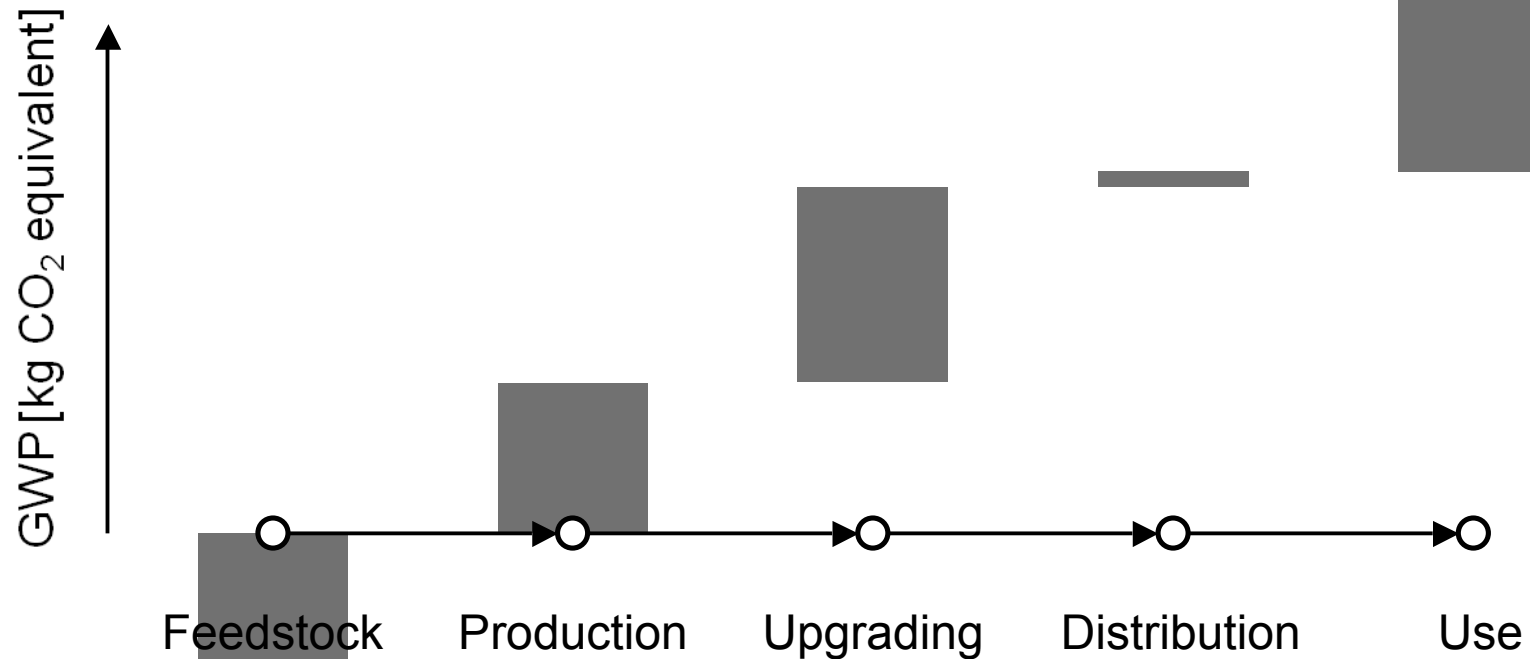

Feedstock generation

- **Municipal organic waste**
 - Life cycle accounted for in original product system
 - Waste considered “burden free” in biomethane system

- **Sewage sludge**
 - Same as municipal waste

- **Dedicated biomass production**
 - Feedstock produced exclusively for digestion to biogas
 - Environmental burden of production attributed to biomethane



Environmental impact (climate)

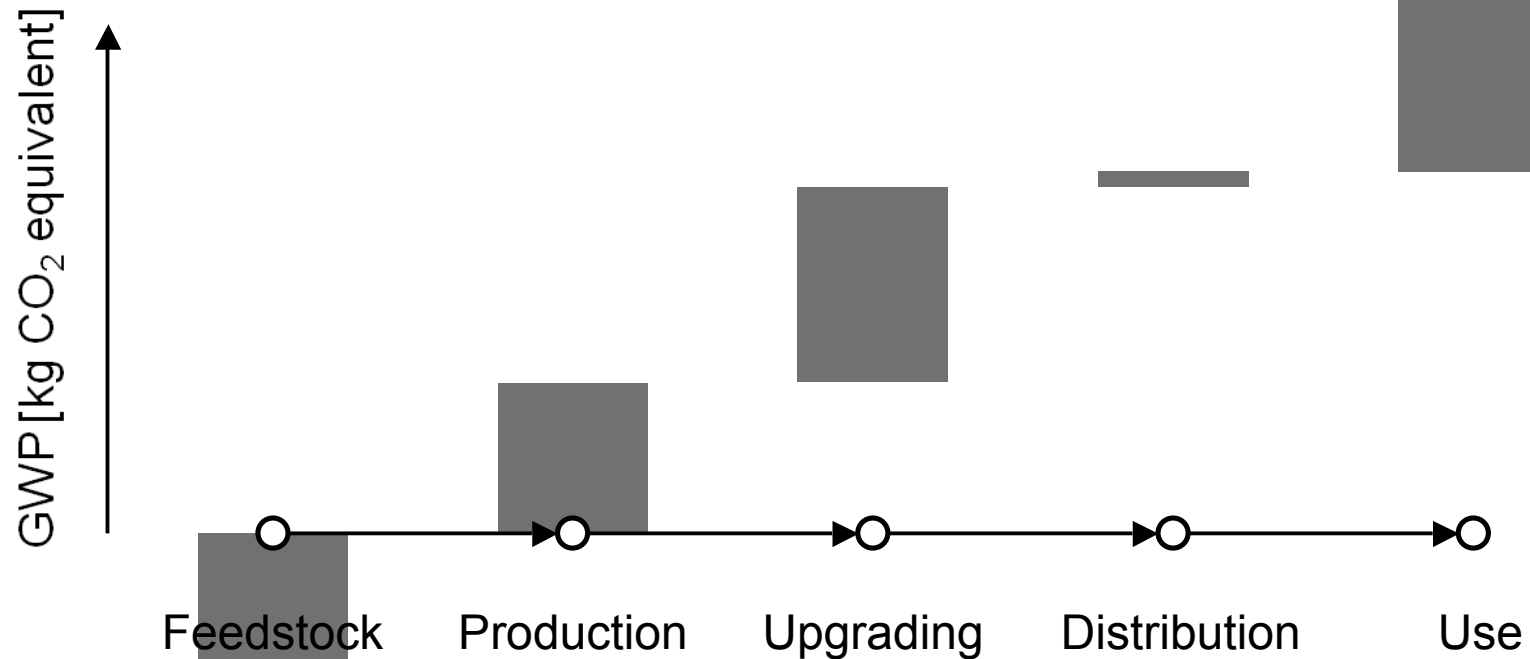

Environmental impact (climate)

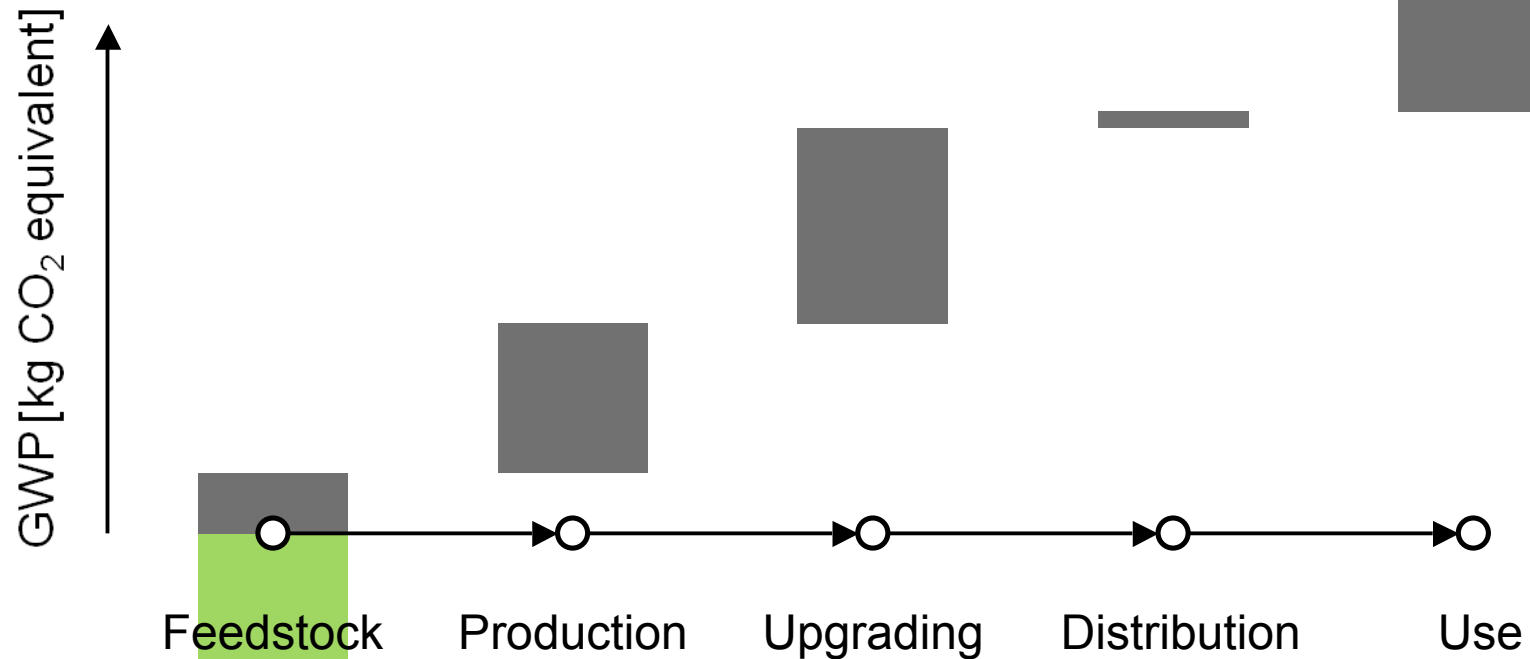

Biogenic CO₂ = part of the natural carbon cycle



Environmental impact (climate)

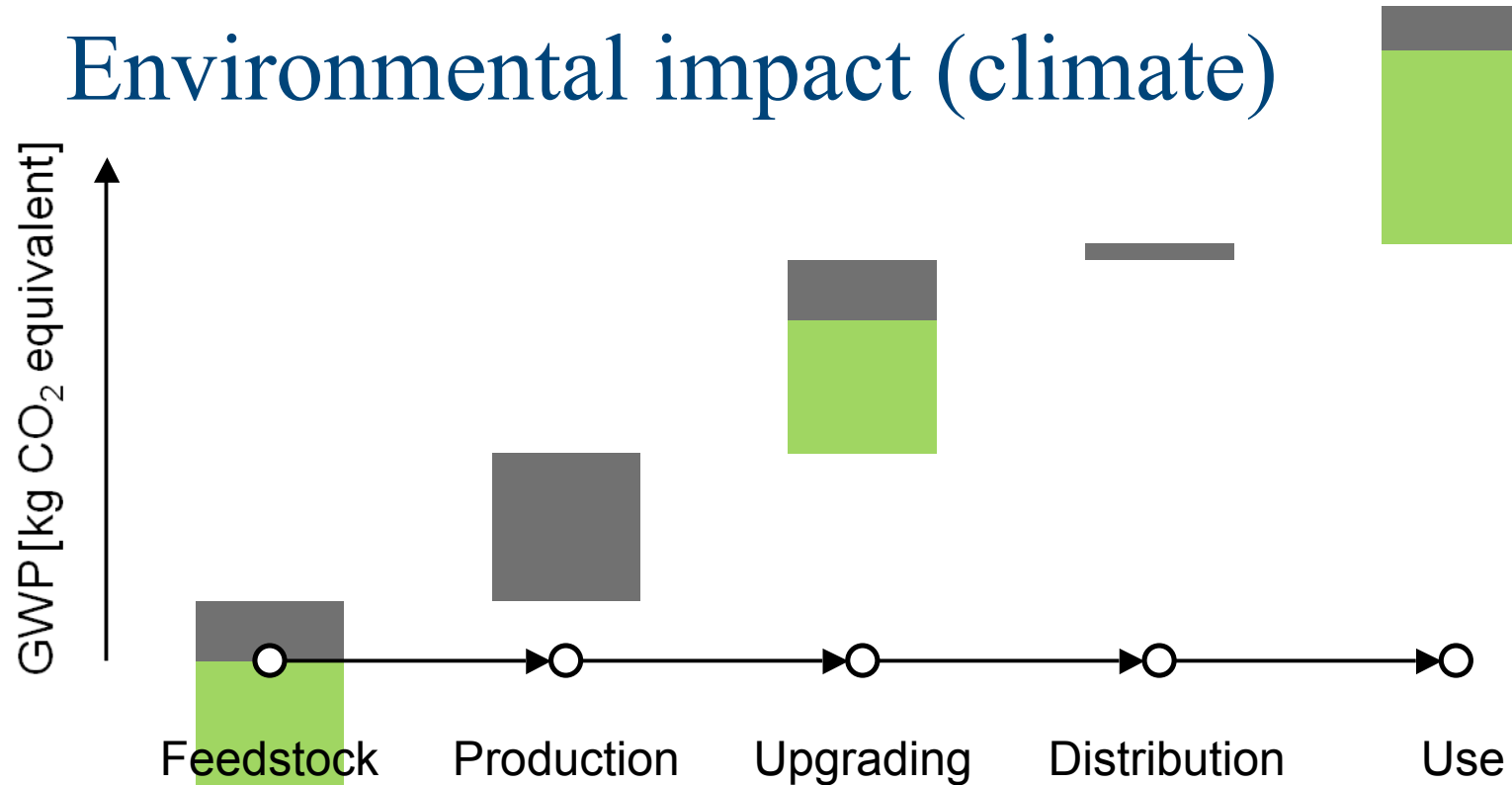

Biogenic CO₂ = part of the natural carbon cycle



Digestion

- Heat management
 - Dry matter content of slurry defines heat demand
 - Impact depends on type of fuel, combustion conditions

- Biogas slip from digester
 - Potentially important GWP and POCP contribution

- Residue valorisation
 - Fertiliser
 - Combustible
 - Filler material



Environmental impact (climate)

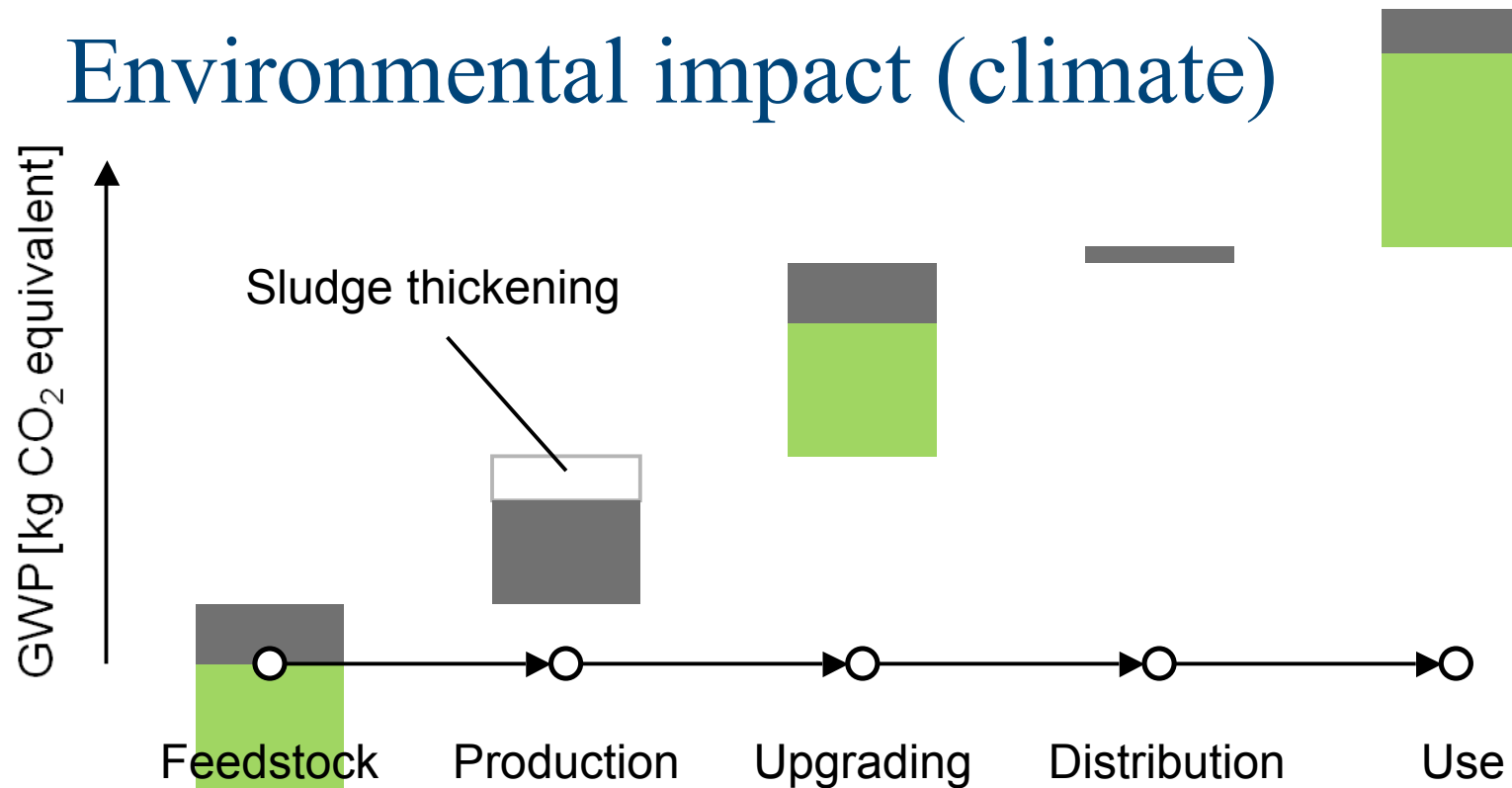

Environmental impact (climate)

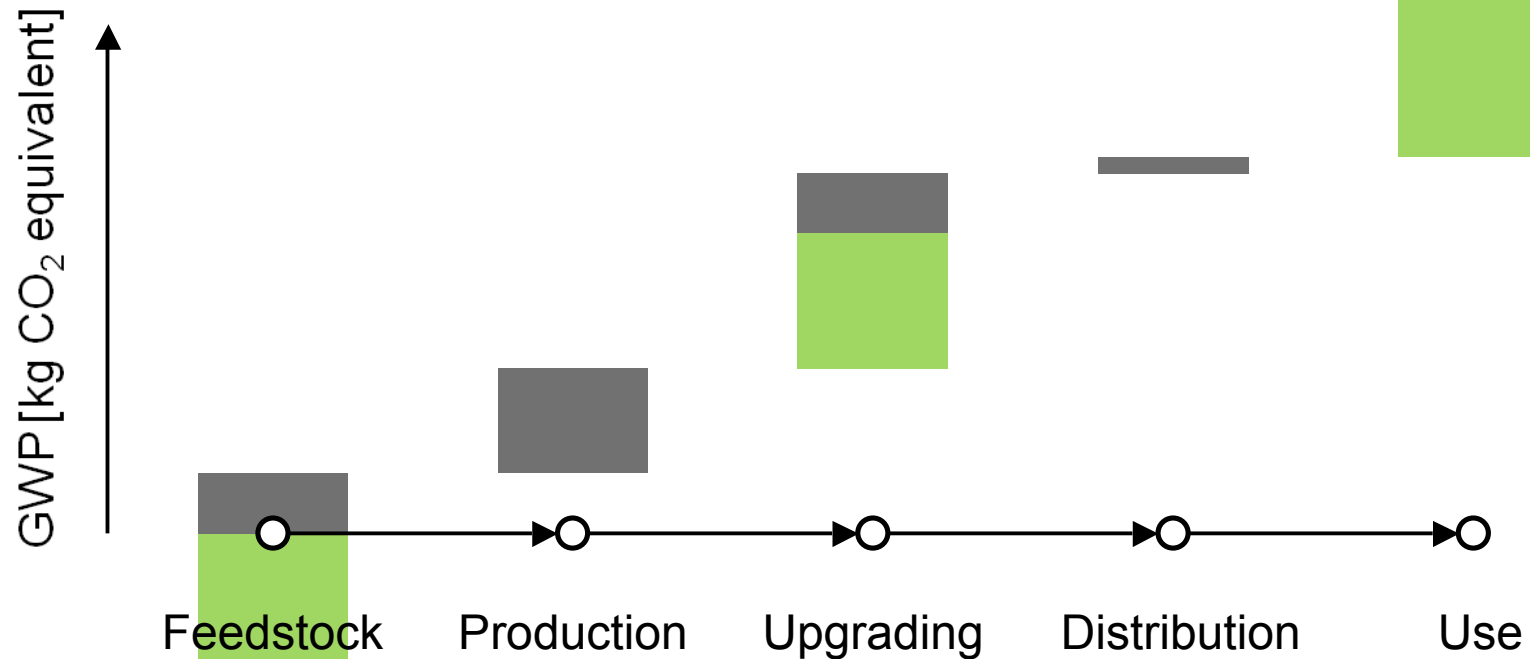

Environmental impact (climate)

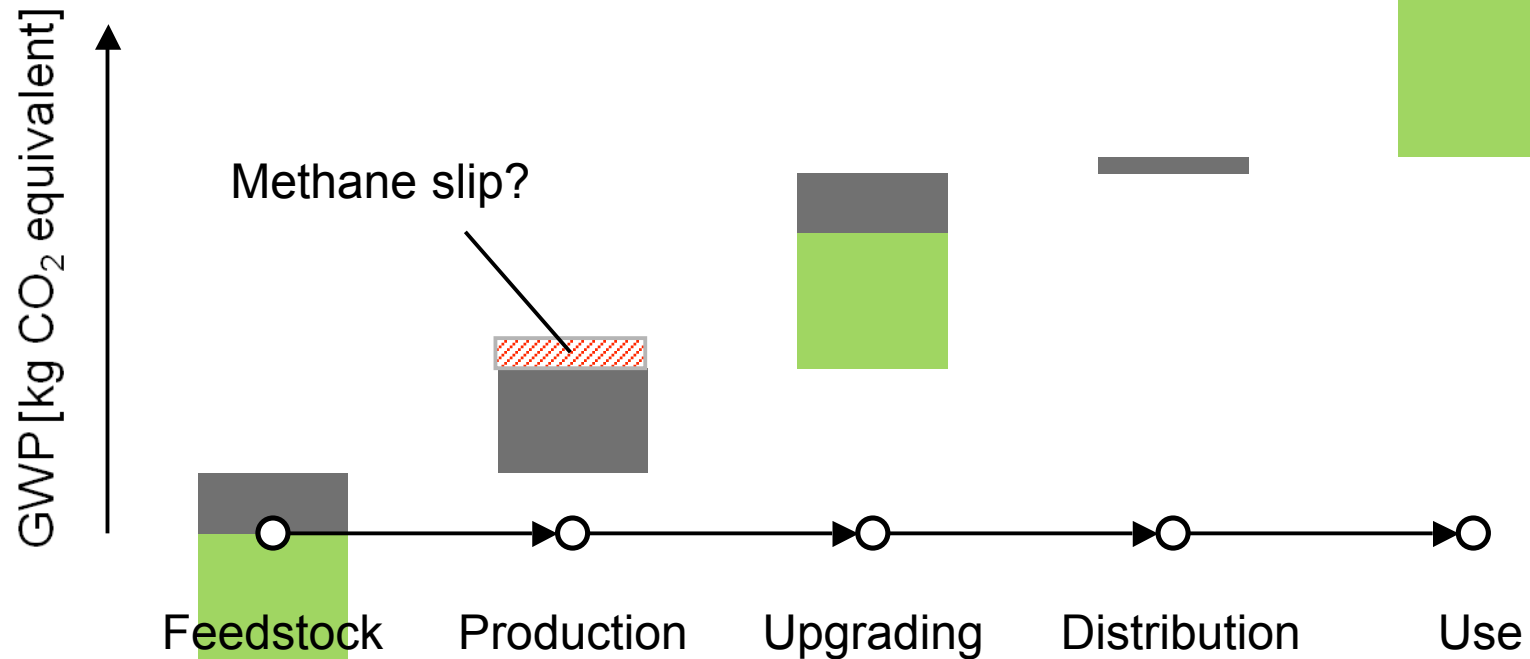

Environmental impact (climate)

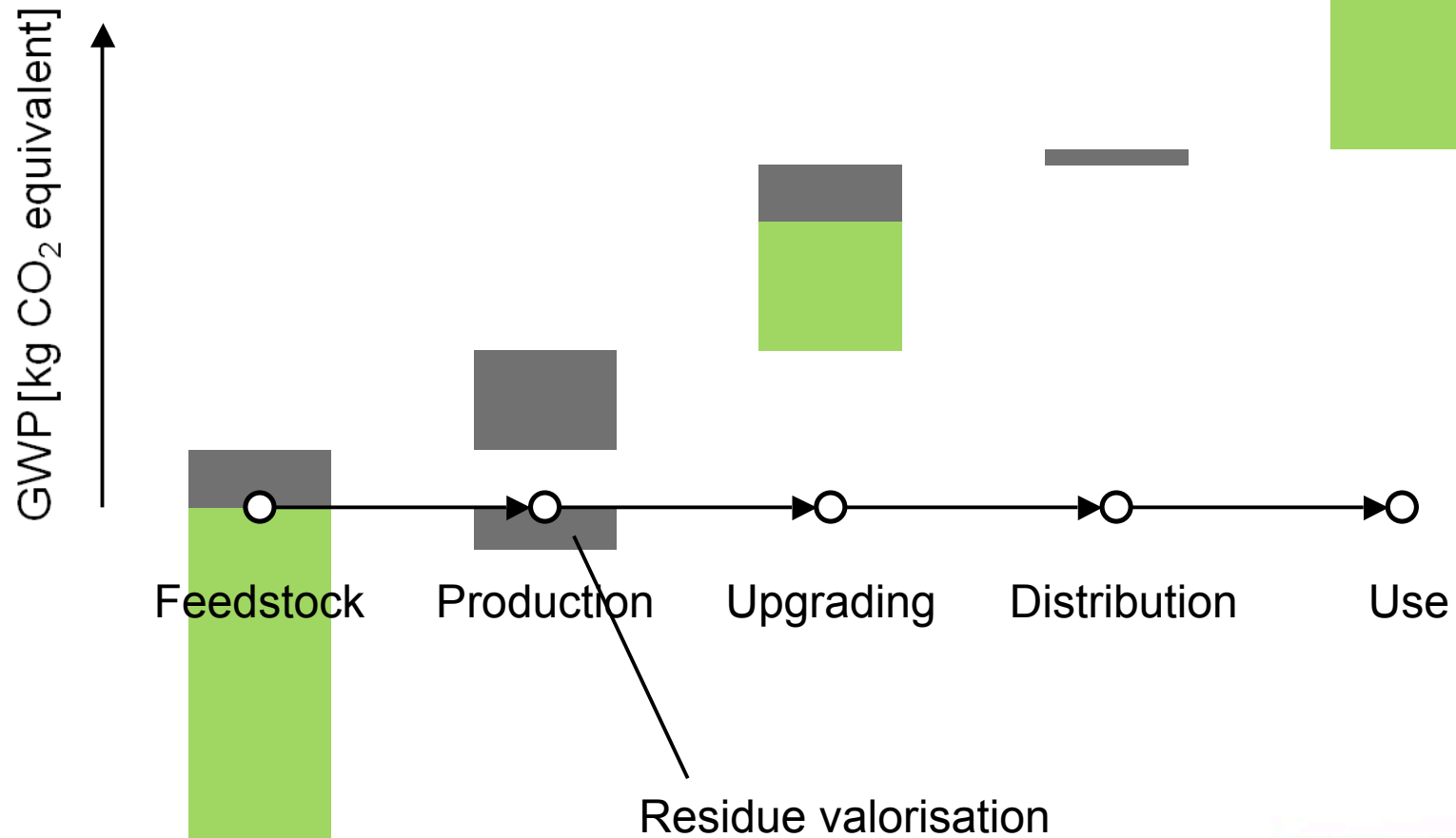

Environmental impact (climate)

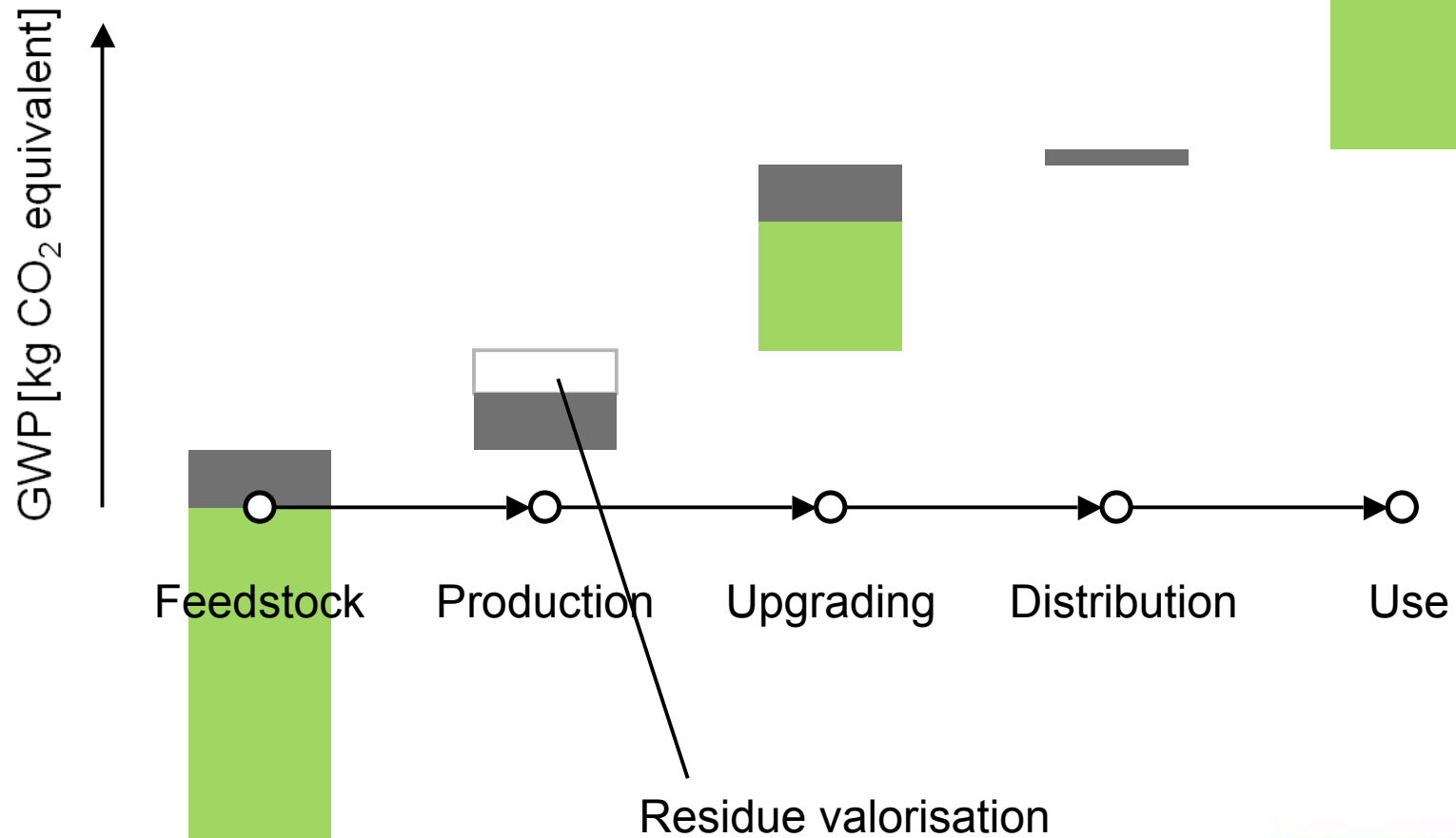

Environmental impact (climate)

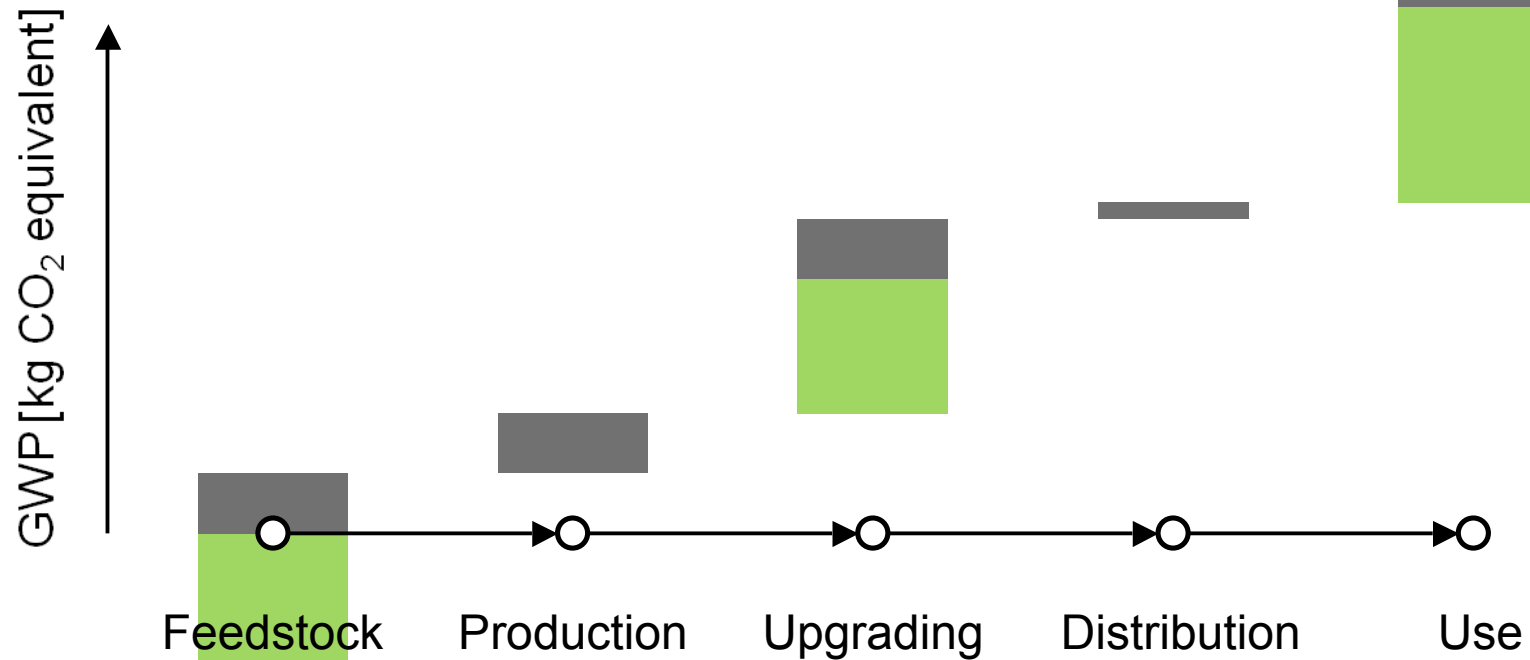

Digestion

- District heating
 - Mostly waste heat from industry → considered “renewable”

- Landfill gas
 - Contains ca. 40% methane and lots of impurities
 - Combustion for heat rather than upgrading
 - Landfill emissions allocated based on revenue shares generated from waste disposal and gas sales



Environmental impact (climate)

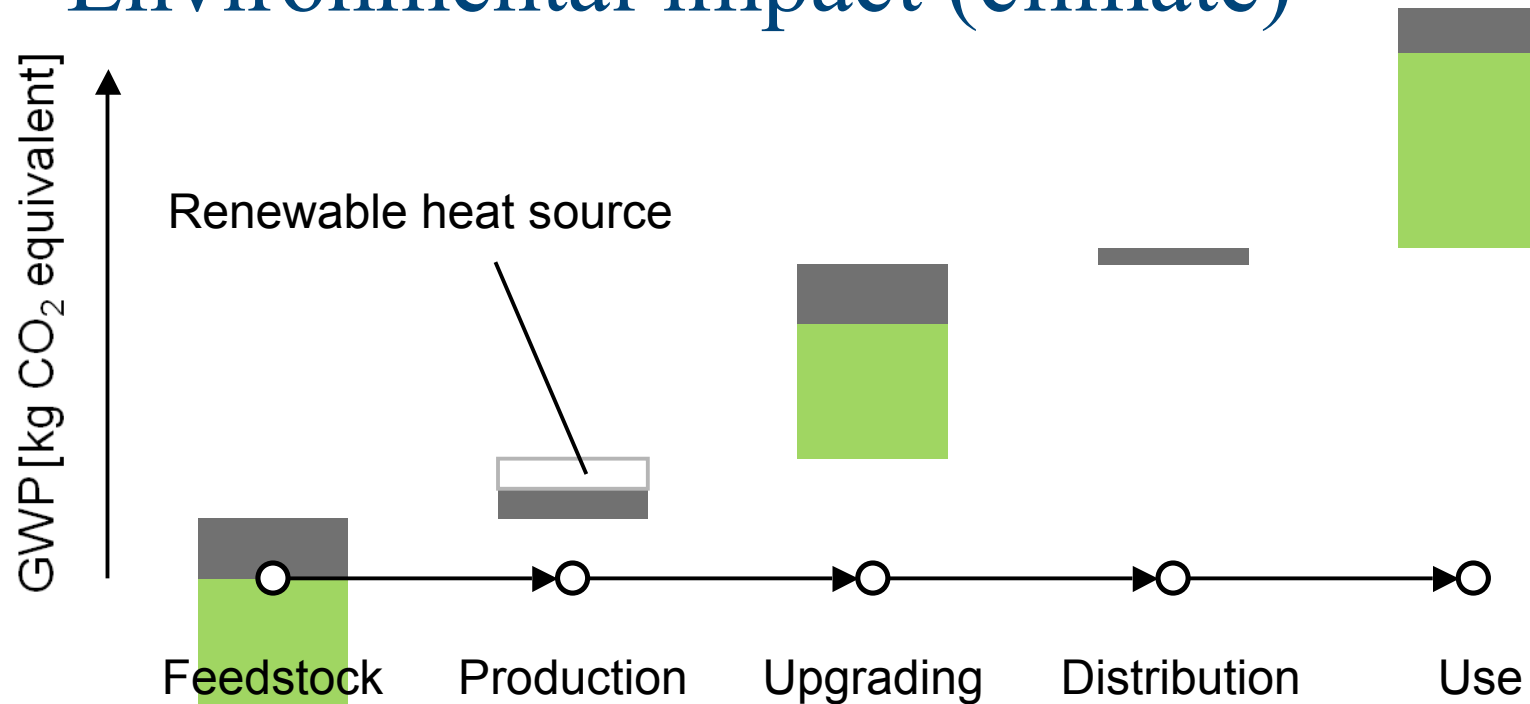

Environmental impact (climate)

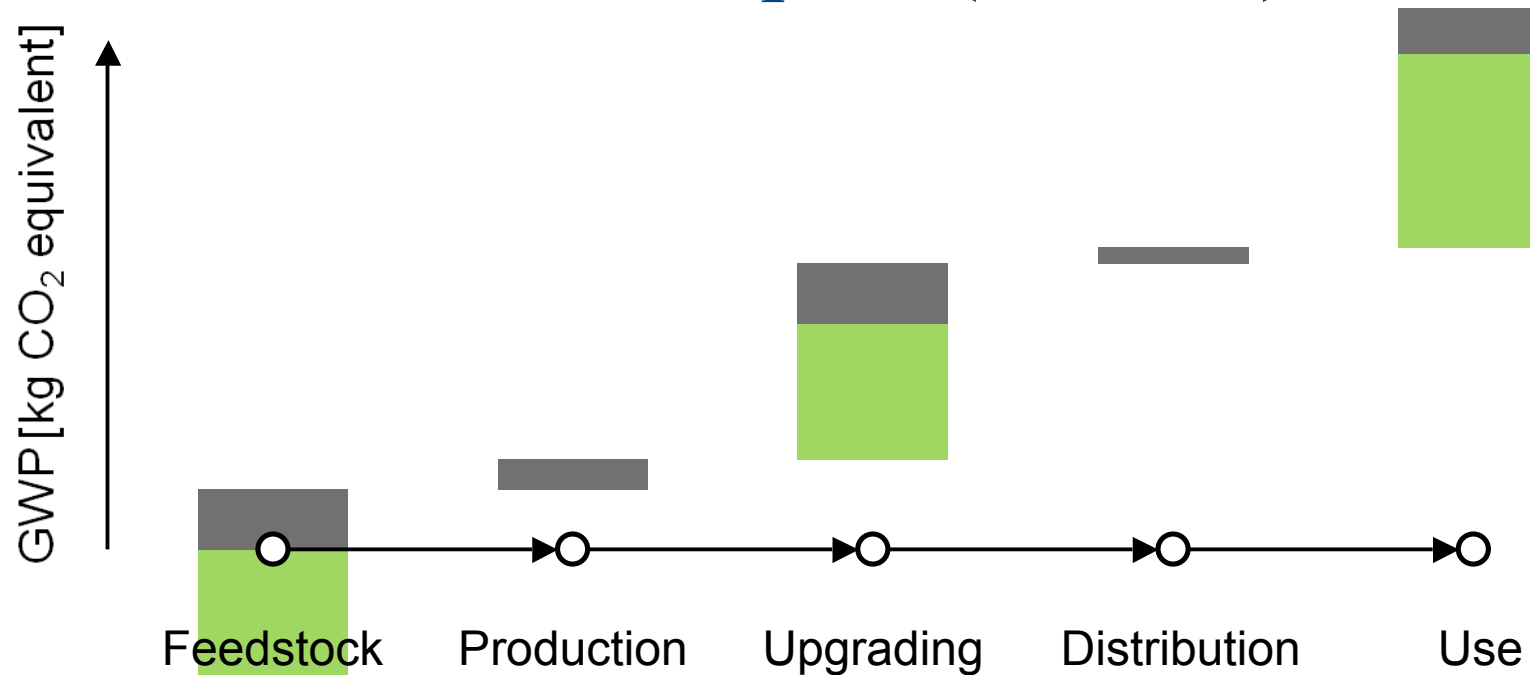

Upgrading

- Water scrubbing, PSA
 - Electricity consumption decisive

- Chemical absorption
 - Heat consumption decisive

- Methane slip
 - Important GWP and POCP contribution
 - Several mitigation measures exist



Environmental impact (climate)

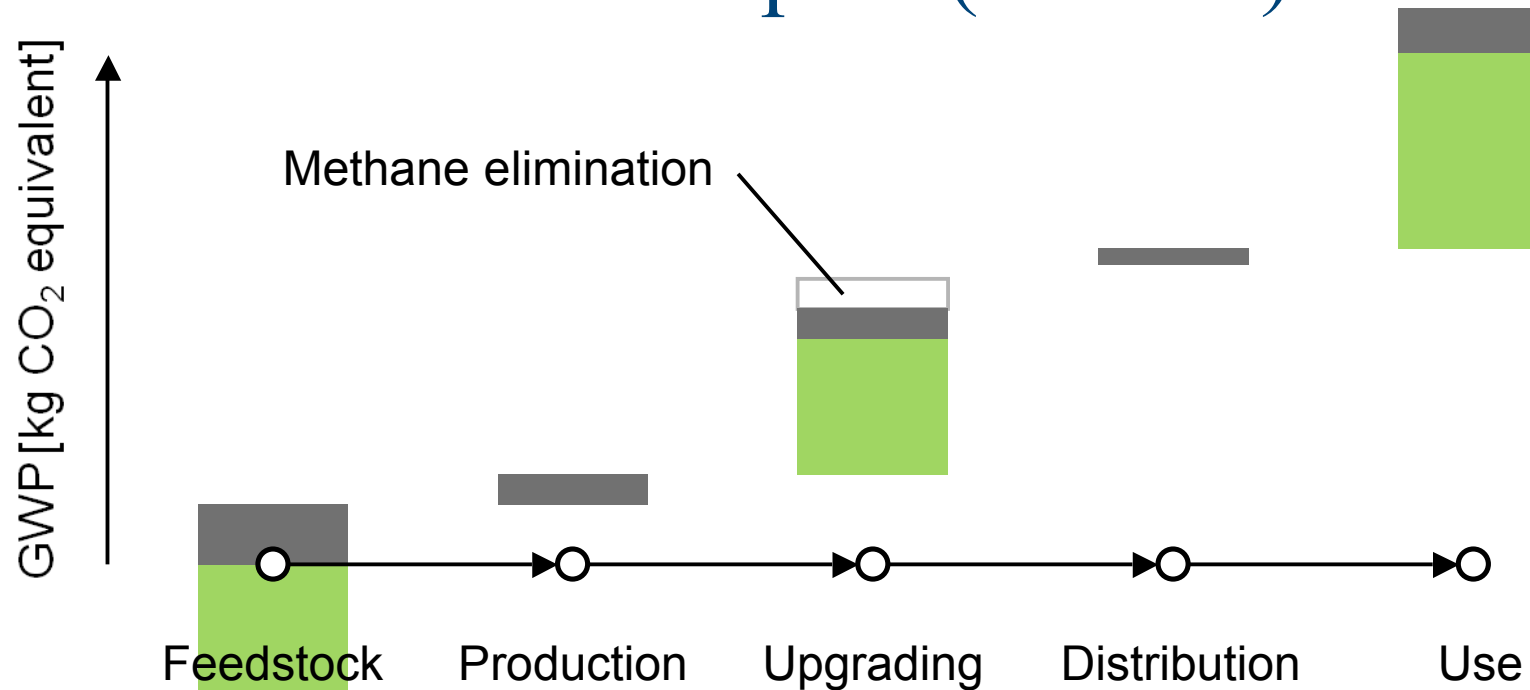

Environmental impact (climate)

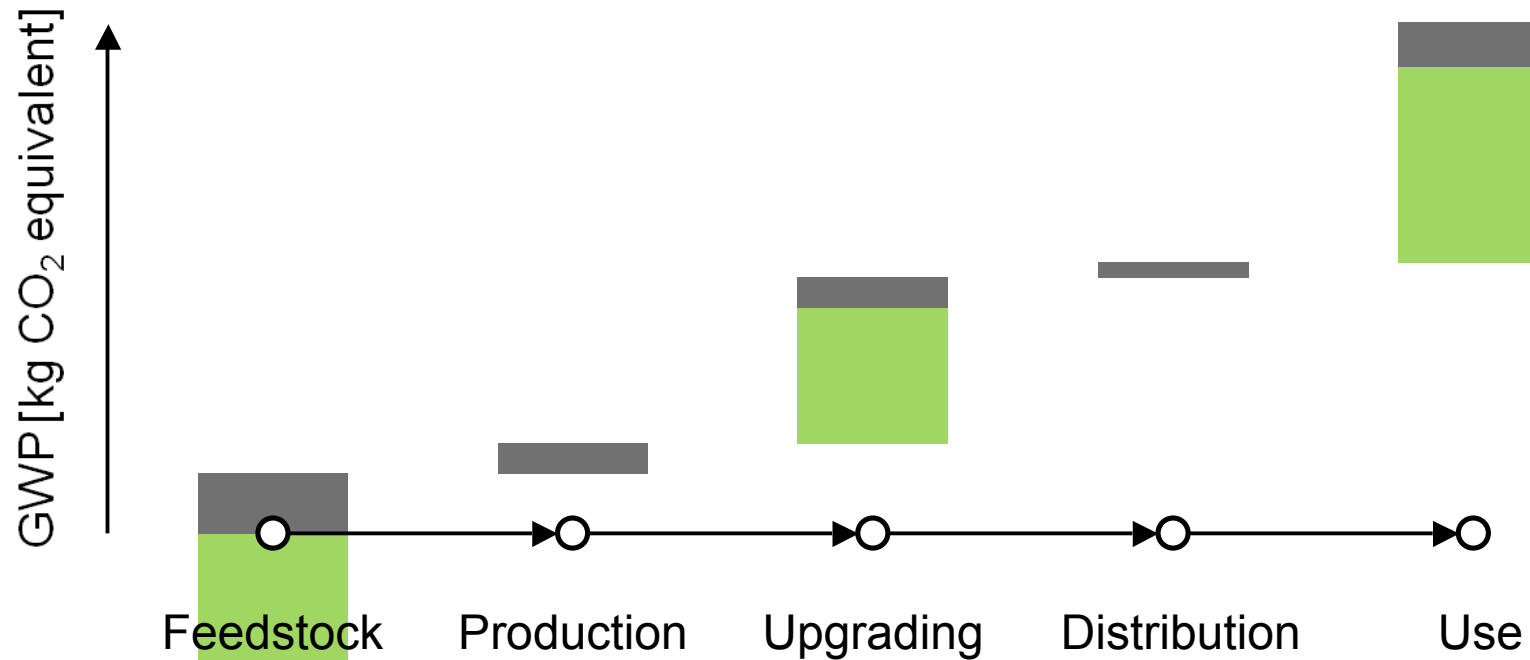

Distribution

- Truck transport
 - Not assessed yet

- Pipeline transport
 - Little influence on overall result
 - Methane slip potentially important GWP, POCP contribution

- Filling stations
 - Little influence on overall result
 - Methane slip potentially important GWP, POCP contribution



Environmental impact (climate)

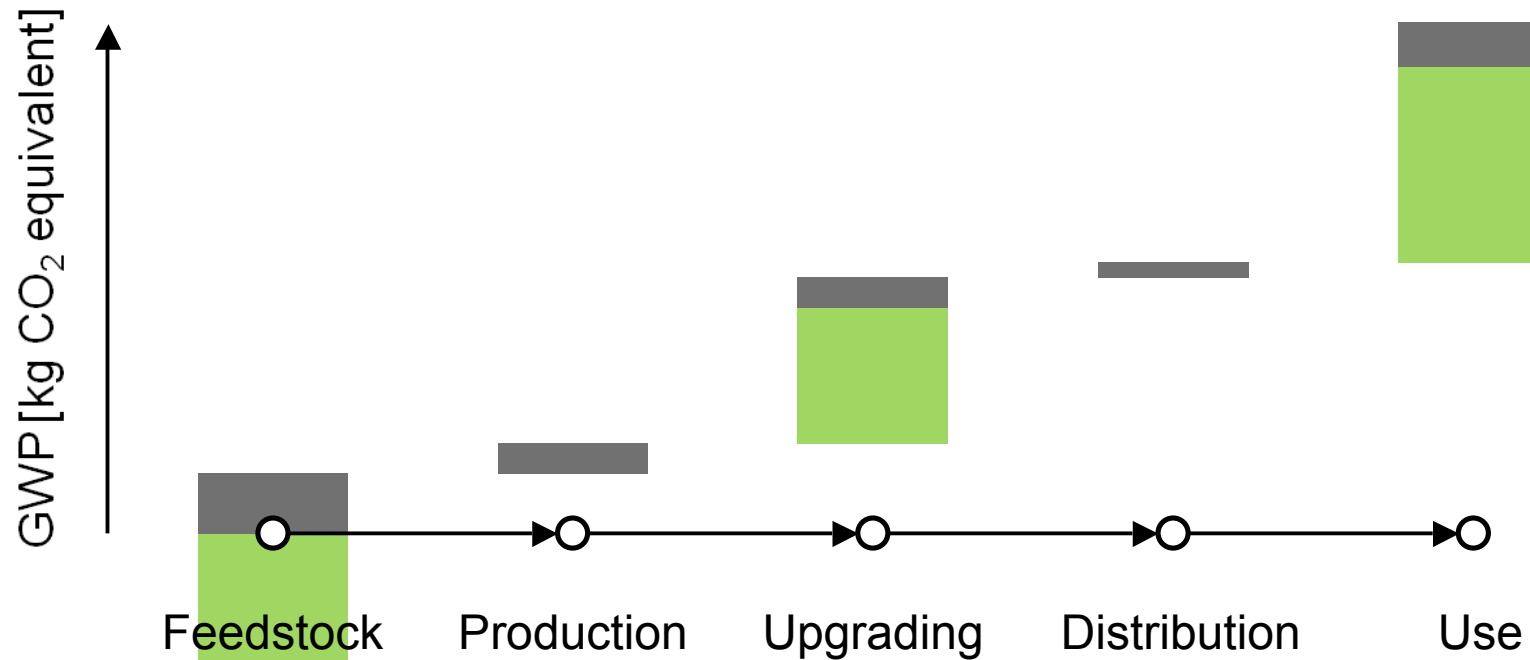

Environmental impact (climate)

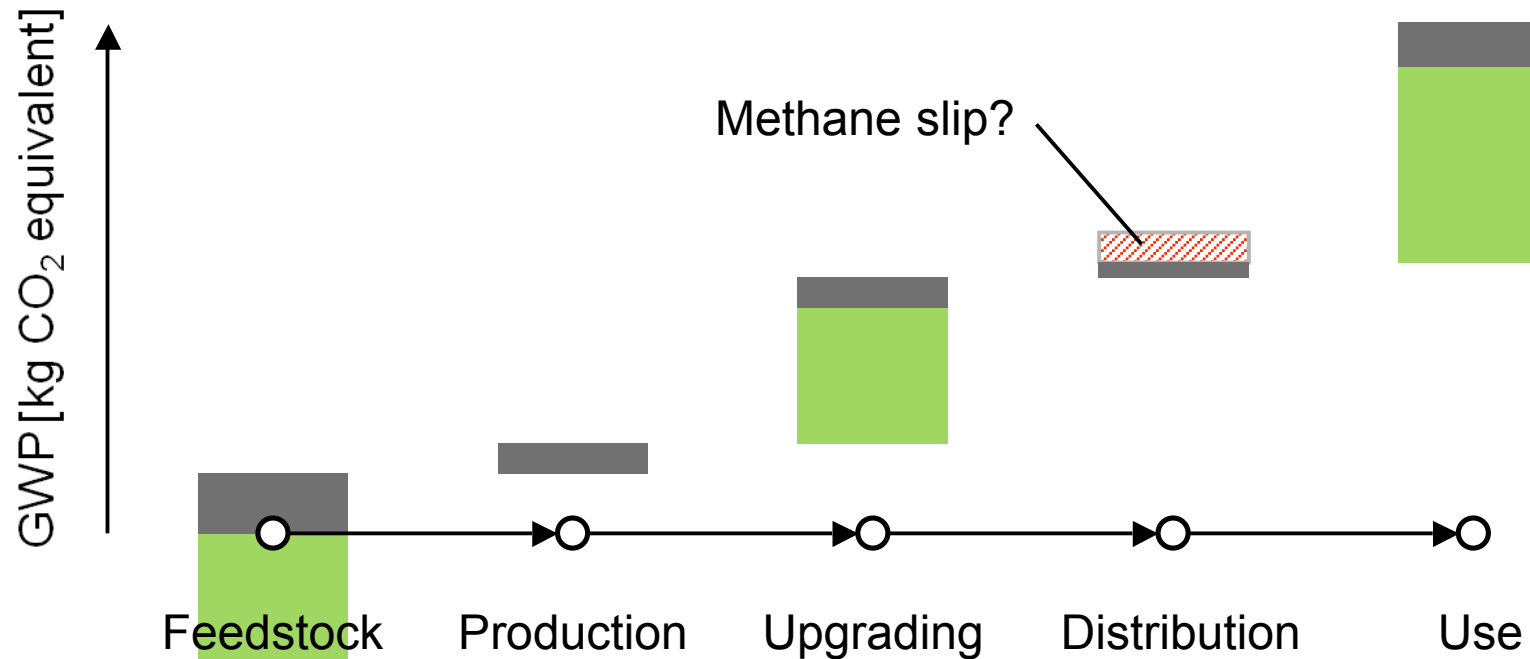

Use

- Vehicles
 - Busses
 - Heavy duty vehicles, e.g. garbage trucks
 - Cabs, private cars



Environmental impact (climate)

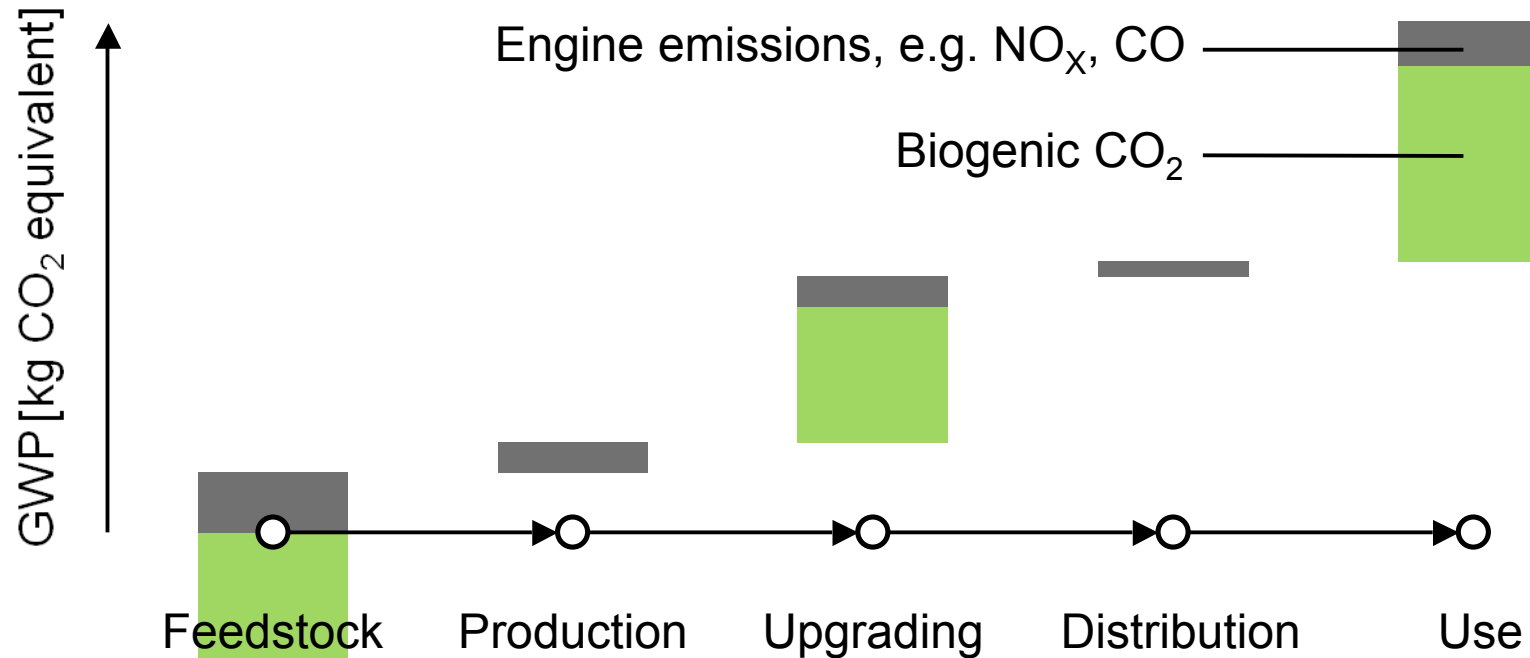

Conclusion

- **Climate/carbon neutrality of Biomethane**
 - Low climate impact, though not 100% climate neutral
 - Considerable improvement potential (technology just stretching into market)
- **Critical points for climate impact**
 - Reduction of methane slip at every stage
 - Valorisation of by-products
- **Presentation limited to climate impacts**
 - Other impacts may (and do) behave differently



Contact

Dipl.-Ing. Jan Paul Lindner
Dept. Life Cycle Engineering (GaBi)
Chair of Building Physics (LBP)
Universität Stuttgart
Hauptstr. 113
70771 Echterdingen
Phone +49-711-489999-25
Fax +49-711-489999-11
E-mail jan-paul.lindner@lbp.uni-stuttgart.de

